

# Operation and Parts



## Xtreme-Duty™ Agitator and Packages

3A4032B  
EN

For high-viscosity coatings supplied in 55 gallon (200 liter) open-headed drums. For professional use only.



### Important Safety Instructions

Read all warnings and instructions in this manual and in related manuals. Save all instructions.

*100 psi (7.0 bar, 0.7 MPa) Maximum Air Input Pressure*

*See page 3 for model information.*

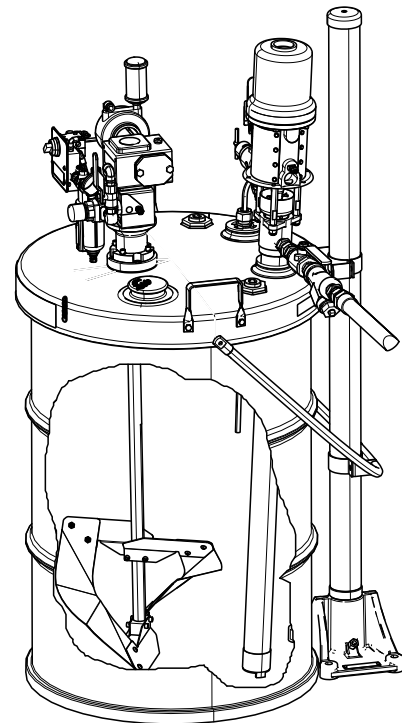

ti28799a



PROVEN QUALITY. LEADING TECHNOLOGY.

# Contents

Related Manuals .....	3	Using the Agitator .....	14
Model Information.....	3	Using the Feed Pump(included in some packages) .....	14
Warnings .....	4	Service .....	15
System Component Identification.....	7	Flushing the Agitator Air Motor .....	15
Installation.....	8	Lubricating the Agitator Air Motor .....	15
Grounding .....	8	Notes.....	16
Assembling and Positioning the Agitator .....	9	Parts.....	17
Attaching the Blades .....	10	Xtreme-Duty Agitator 25A598 .....	17
Air Connections .....	11	Xtreme-Duty Agitator Drive Train .....	18
Fluid Accessories.....	12	Xtreme-Duty Agitator Packages 25A599 – 25A604 .....	20
Operation.....	13	Technical Data .....	21
Pressure Relief Procedure.....	13	Graco Standard Warranty.....	22
Setup.....	13		
Using the Elevator (included in some packages) .....	14		



## Related Manuals

Component Manuals in English:

Manual	Description
306287	Elevators and pump supports
308118	SST feed pumps, 5:1 and 10:1 ratio
307044	CS feed pump, 5:1 ratio
308738	CS feed pump, 10:1 ratio
307043	Monark® air motors
306982	President® air motors

## Model Information

For maximum air and fluid working pressures and agency approvals of package components, see appropriate component manual.





<b>Model 25A598</b>	Xtreme-Duty Agitator		 II 1/2 G c IIC T4 ITS 16 ATEX 100984 0°C≤Ta≤50°C
---------------------	----------------------	--	---



### List of Packages

Package	Agitator	Mounting	Support	Feed Pump	Approvals
<b>25A599</b> AGITATOR ON DRUM COVER	Xtreme-Duty Agitator 25A598	Drum cover with recirculation kit	Handles on drum cover	-----	
<b>25A600</b> AGITATOR WITH ELEVATOR	Xtreme-Duty Agitator 25A598	Drum cover with recirculation kit	Elevator with support attachments	-----	
<b>25A601</b> AGITATOR WITH ELEVATOR AND FEED	Xtreme-Duty Agitator 25A598	Drum cover with feed and recirculation kit	Elevator with support attachments	5:1 CS Monark	
<b>25A602</b> AGITATOR WITH ELEVATOR AND FEED	Xtreme-Duty Agitator 25A598	Drum cover with feed and recirculation kit	Elevator with support attachments	5:1 SST Monark	
<b>25A603</b> AGITATOR WITH ELEVATOR AND FEED	Xtreme-Duty Agitator 25A598	Drum cover with feed and recirculation kit	Elevator with support attachments	10:1 CS President	
<b>25A604</b> AGITATOR WITH ELEVATOR AND FEED	Xtreme-Duty Agitator 25A598	Drum cover with feed and recirculation kit	Elevator with support attachments	10:1 SST President	

# Warnings

The following warnings are for the setup, use, grounding, maintenance, and repair of this equipment. The exclamation point symbol alerts you to a general warning and the hazard symbols refer to procedure-specific risks. When these symbols appear in the body of this manual or on warning labels, refer back to these Warnings. Product-specific hazard symbols and warnings not covered in this section may appear throughout the body of this manual where applicable.

 <h2 style="margin: 0;">WARNING</h2>	
	<p><b>FIRE AND EXPLOSION HAZARD</b></p> <p>Flammable fumes, such as solvent and paint fumes, in <b>work area</b> can ignite or explode. Paint or solvent flowing through the equipment can cause static sparking. To help prevent fire and explosion:</p> <ul style="list-style-type: none"> <li>• Use equipment only in well ventilated area.</li> <li>• Eliminate all ignition sources; such as pilot lights, cigarettes, portable electric lamps, and plastic drop cloths (potential static sparking).</li> <li>• Ground all equipment in the work area. See <b>Grounding</b> instructions.</li> <li>• Never spray or flush solvent at high pressure.</li> <li>• Keep work area free of debris, including solvent, rags and gasoline.</li> <li>• Do not plug or unplug power cords, or turn power or light switches on or off when flammable fumes are present.</li> <li>• Use only grounded hoses.</li> <li>• Hold gun firmly to side of grounded pail when triggering into pail. Do not use pail liners unless they are anti-static or conductive.</li> <li>• <b>Stop operation immediately</b> if static sparking occurs or you feel a shock. Do not use equipment until you identify and correct the problem.</li> <li>• Keep a working fire extinguisher in the work area.</li> </ul>
	<p><b>PRESSURIZED EQUIPMENT HAZARD</b></p> <p>Fluid from the equipment, leaks, or ruptured components can splash in the eyes or on skin and cause serious injury.</p> <ul style="list-style-type: none"> <li>• Follow the <b>Pressure Relief Procedure</b> when you stop spraying/dispensing and before cleaning, checking, or servicing equipment.</li> <li>• Tighten all fluid connections before operating the equipment.</li> <li>• Check hoses, tubes, and couplings daily. Replace worn or damaged parts immediately.</li> </ul>
	<p><b>MOVING PARTS HAZARD</b></p> <p>Moving parts can pinch, cut or amputate fingers and other body parts.</p> <ul style="list-style-type: none"> <li>• Keep clear of moving parts.</li> <li>• Do not operate equipment with protective guards or covers removed.</li> <li>• Pressurized equipment can start without warning. Before checking, moving, or servicing equipment, follow the <b>Pressure Relief Procedure</b> and disconnect all power sources.</li> </ul>

 <b>WARNING</b>	
	<p><b>TOXIC FLUID OR FUMES HAZARD</b></p> <p>Toxic fluids or fumes can cause serious injury or death if splashed in the eyes or on skin, inhaled, or swallowed.</p> <ul style="list-style-type: none"><li>• Read Safety Data Sheet (SDS) to know the specific hazards of the fluids you are using.</li><li>• Store hazardous fluid in approved containers, and dispose of it according to applicable guidelines.</li></ul>
	<p><b>PERSONAL PROTECTIVE EQUIPMENT</b></p> <p>Wear appropriate protective equipment when in the work area to help prevent serious injury, including eye injury, hearing loss, inhalation of toxic fumes, and burns. Protective equipment includes but is not limited to:</p> <ul style="list-style-type: none"><li>• Protective eyewear, and hearing protection.</li><li>• Respirators, protective clothing, and gloves as recommended by the fluid and solvent manufacturer.</li></ul>

# WARNING



## EQUIPMENT MISUSE HAZARD

Misuse can cause death or serious injury.



- Do not operate the unit when fatigued or under the influence of drugs or alcohol.
- Do not exceed the maximum working pressure or temperature rating of the lowest rated system component. See **Technical Data** in all equipment manuals.
- Use fluids and solvents that are compatible with equipment wetted parts. See **Technical Data** in all equipment manuals. Read fluid and solvent manufacturer's warnings. For complete information about your material, request Safety Data Sheet (SDS) from distributor or retailer.
- Turn off all equipment and follow the **Pressure Relief Procedure** when equipment is not in use.
- Check equipment daily. Repair or replace worn or damaged parts immediately with genuine manufacturer's replacement parts only.
- Do not alter or modify equipment. Alterations or modifications may void agency approvals and create safety hazards.
- Make sure all equipment is rated and approved for the environment in which you are using it.
- Use equipment only for its intended purpose. Call your distributor for information.
- Route hoses and cables away from traffic areas, sharp edges, moving parts, and hot surfaces.
- Do not kink or over bend hoses or use hoses to pull equipment.
- Keep children and animals away from work area.
- Comply with all applicable safety regulations.

# System Component Identification

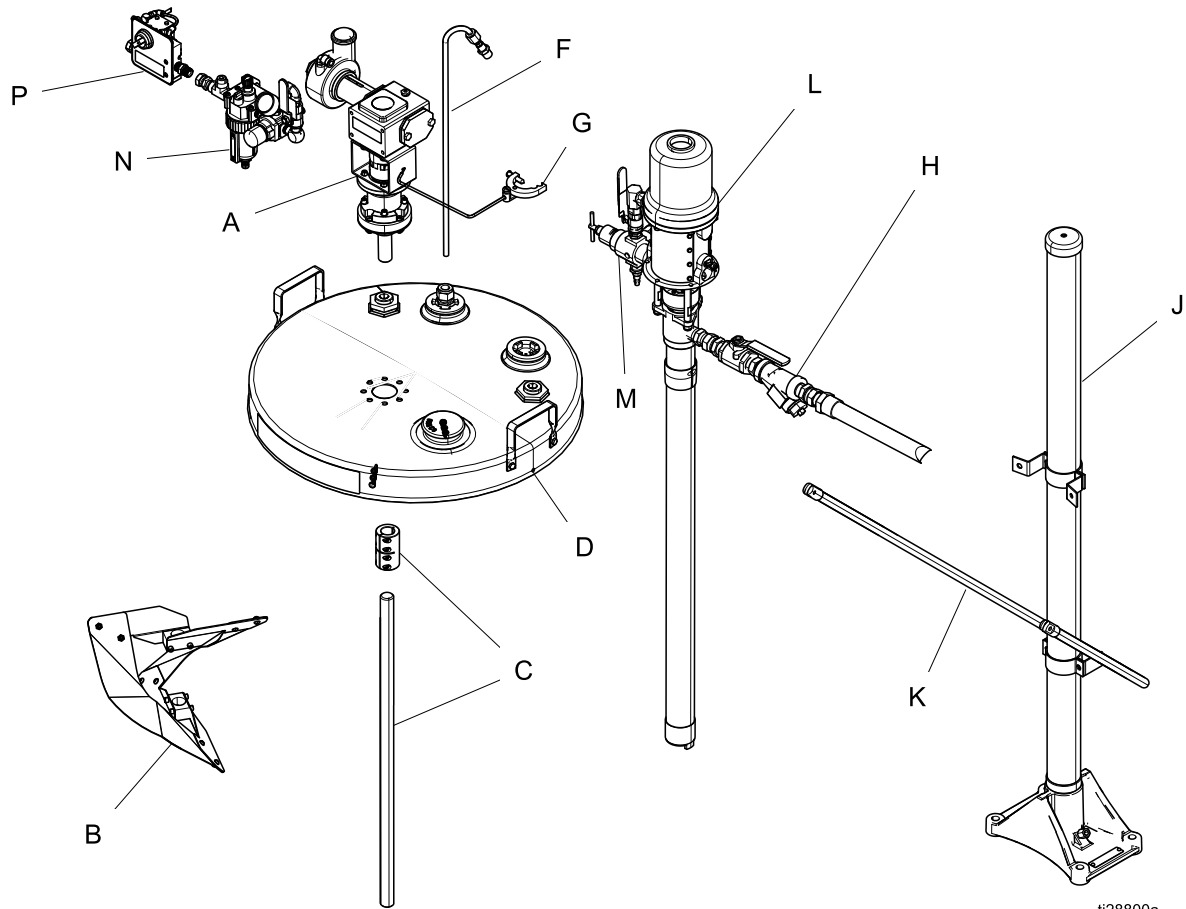

ti28800a

**Key:**

- A Agitator air motor and gear reducer
- B Xtreme-Duty agitator blade
- C Agitator shaft and coupler
- D Stainless steel drum cover
- F Recirculation tube
- G Ground wire with clamp
- H Feed pump strainer

**Key:**

- J Drum cover elevator
- K Drum cover support (for elevator)
- L Feed pump
- M Pump air control
- N Agitator air control
- P Elevator air control

# Installation

## Typical Installation

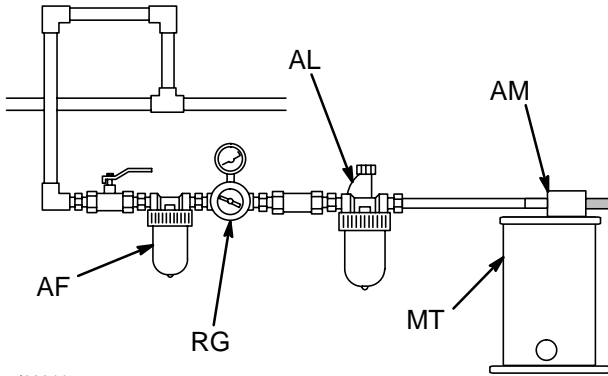

ti28844a

Ref.	Description
AF*	Air Supply Line Filter
AL*	Air Supply Line Lubricator
AM	Agitator Motor
MT*	Mix Tank (reference only)
RG*	Air Regulator and Gauge

\* Items not supplied.

## Grounding

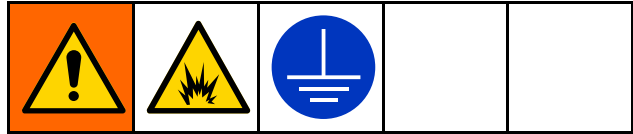

The equipment must be grounded to reduce the risk of static sparking. Static sparking can cause fumes to ignite or explode. Grounding provides an escape wire for the electric current.

To ground the agitator, connect one end of the ground wire (G) to the ground connector (GC) on the side of the agitator and/or drum cover. Connect the clamp end of the ground wire to a true earth ground.

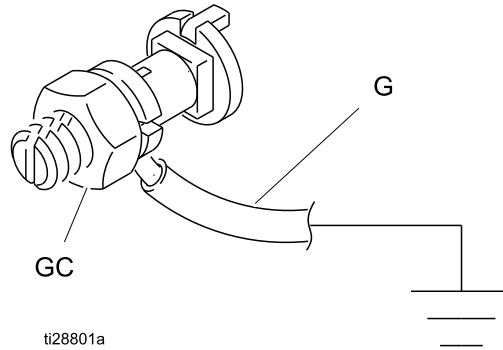

For an additional ground wire and clamp, order Part 237569.





ti28801a



## Assembling and Positioning the Agitator

				
<p>To reduce the risk of fire and explosion, always maintain a minimum of 1 in. clearance inside the material drum between rotating agitator parts and any other objects, including the drum to prevent sparks from contact. This includes the edges of the drum as well as any item which may be inserted into the drum from another opening, such as feed pumps or suction tubes.</p>				

## With an Elevator

				
<p>To reduce the risk of injury from being crushed by equipment, do not go under the elevator when it is raised.</p>				

Mount the drum cover as described in the Elevators and Pump Supports Manual 306287. The elevator must be in the down position when you do any work on the elevator, agitator, or drum cover assembly.

## Without an Elevator

When included in a package without an elevator, the drum cover is provided with handles for easy lifting and positioning. For additional handles, order the Handles Kit, part 237524.

Place two standard 55 U.S. gallon (45 Imperial gallon, 200 L) drums 14 in. (36 cm) apart, and center the drum cover on the barrels.

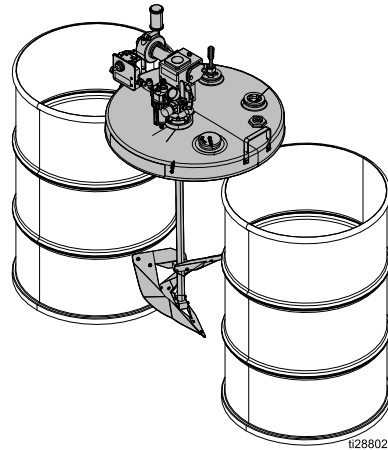

1. Install the four lock nuts (A2) holding the agitator to the drum cover.

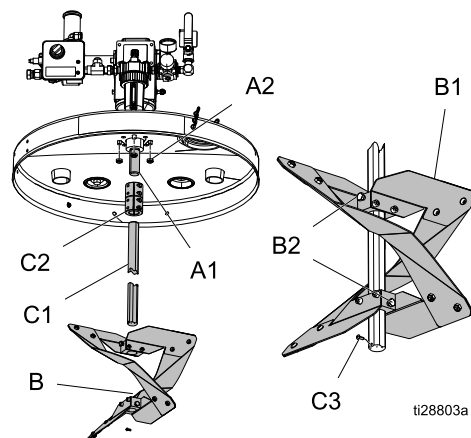

2. Tighten the lock nuts to 30 ft-lb (40.6 N•m).

## Securing the Drum Cover

The drum cover must be secured to the drum to ensure proper clearance of rotating parts and prevent vibration. If using the drum cover without an elevator, the cover must be secured by clamping or other means. For open-headed drums with closing ring, make sure the lever-lock or closing bolt is fastened securely before operating.

## Using a Custom Drum Cover

If the Xtreme-Duty agitator is being mounted on a custom drum cover, sufficient clearance must be provided around any moving parts. See the image below for the hole mounting pattern and minimum clearance required.

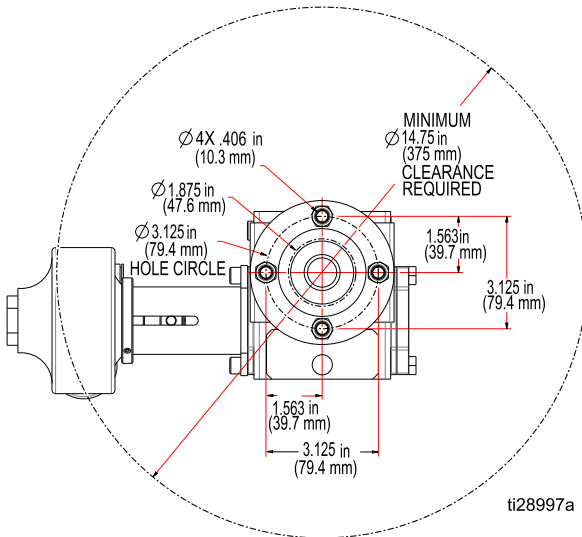

## Attaching the Blades

1. Slide the agitator blade assembly (B1) onto the shaft (C1), positioned so that the blade coupling screws (B2) will contact the flats of the shaft. Apply thread sealant (supplied with the blades) to screws (B2).

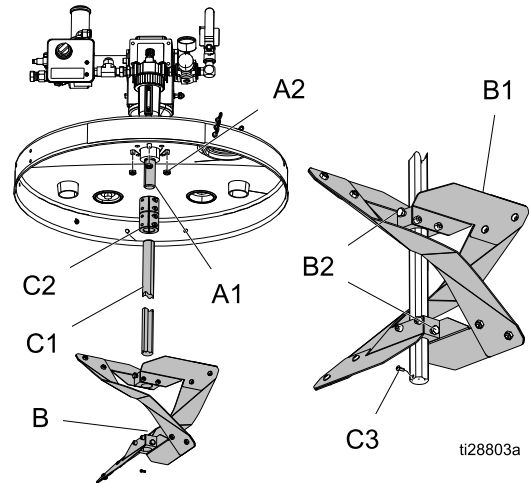

2. Adjust the height of the blade assembly as desired and tighten two screws (B2) to attach the blades onto the shaft. Tighten to 13 ft-lb (17.6 N•m).
3. Apply thread sealant to screw (C3) and tighten to 12–20 in-lb (1.3–2.3 N•m).
4. Slide the shaft coupler (C2) onto the output shaft of the agitator drive (A1) up to the mid point of the coupler screws. Tighten to 15 ft-lb (20 N•m).
5. Slide the blade shaft (C1) into the coupler and tighten two screws to attach the shaft to the coupler. Tighten to 15 ft-lb (20 N•m).

## Air Connections

Connect an electrically conductive 1/2 in. ID (minimum) air hose to supply air to the system air controls. Packages without an elevator will not have an elevator control, and packages without a feed pump will have the connection for the pump air hose plugged. Install an air filter upstream of the system to remove harmful dirt and moisture from the air supply. To order an air filter, order part 106148 (3.8 in. npt, 20-micron element, 5 oz. bowl, without gauge).

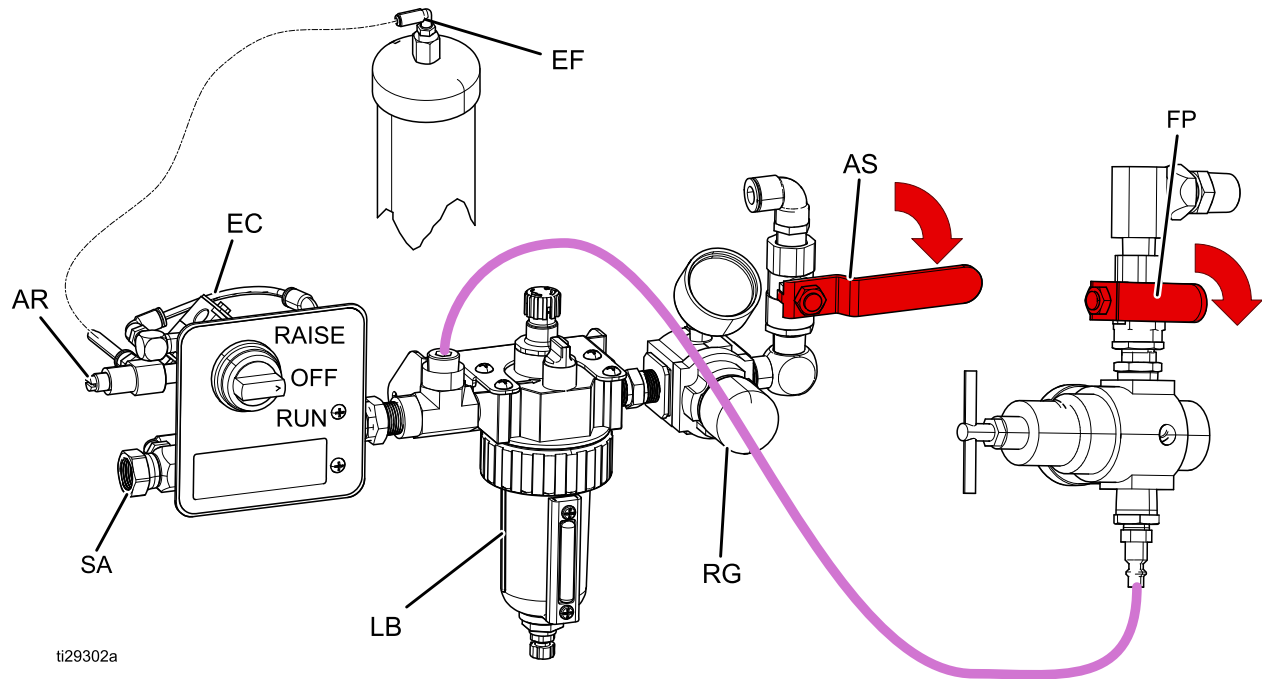

ti29302a

Ref.	Description
AR	Air Restrictor (Elevator Speed)
EC	Elevator Control Selector
AS	Agitator Shut Off Valve
FP	Feed Pump Shut Off Valve
SA	Supply Air Inlet
LB	Agitator Lubricator
RG	Agitator Regulator and Gauge
EF	Elevator Air Fitting

If installing an elevator, reference the Installation section of the Elevators and Pump Supports Manual 306287\*. To connect the elevator air control, insert 1/4 in. OD air tubing into the tube-connect fitting of the resistor valve (AR) on the back of the elevator air control. Insert the other end into the elevator air fitting (AF).

\* Install the elevator air fitting (EF, included with the elevator air control) into the port on top of the elevator riser tube.

## Fluid Accessories

If using a feed pump, insert the pump into one of the two 2 in. npt bungs in the drum cover. The pump may be mounted on either side. Follow the installation instructions in the pump manual.

Connect the air hose from the air control tee fitting to the pump air control. **A bleed-type air valve is included in pump air control part 248829. If you are not using this air control, a bleed-type air valve must be installed.**

A 3/4 in. feed hose is included with some packages. Install the hose into the strainer on the outlet of the pump and connect the other end to the inlet of the proportioning system or other equipment.

A fluid drain valve is required to connect to the fluid outlet of the pump. See the pump manual for details.

The drum cover also has two 1 in. npt ports (which have 1-1/2 in. npt male threads underneath the cover) which can be used for installing refill lines or suction tubes.

A recirculation tube can be inserted into a strain relief bushing installed in one of the two 2 in. bung plugs. The bung plug has a 1/2 in. ID knockout feature which keeps the bung sealed if a recirculation tube is not used.

To install a recirculation tube, remove the strain relief bushing from the bung plug and place a tube, punch or other item against the knockout and strike with a hammer. Make sure that any plastic is cleared from the underside of the plug.

Once the knockout is removed, reinstall the strain relief bushing and insert the recirculation tube. Tighten the bushing against the tube to seal and hold in place.

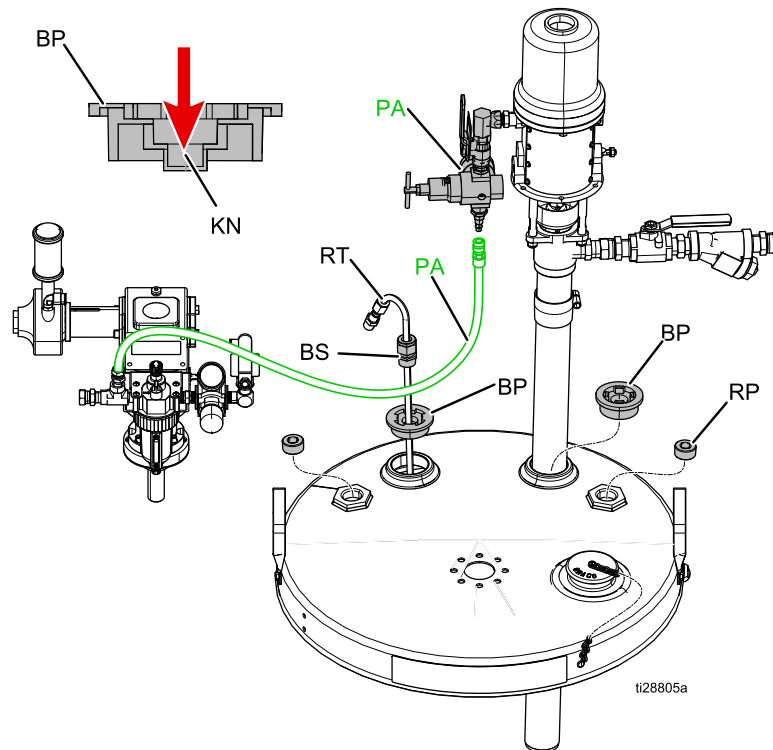

Ref.	Description
BP	Bung Plug
KN	Knockout
PA	Pump Air Controls
RT	Recirculation Tube

Ref.	Description
BS	Bushing
PA	Pump Air Hose
BP	Bung Plug
RP	Refill Port

# Operation

## Pressure Relief Procedure



Follow the Pressure Relief Procedure whenever you see this symbol.



This equipment stays pressurized until pressure is manually relieved. To help prevent serious injury from pressurized fluid such as splashing fluid and moving parts, follow the Pressure Relief Procedure before cleaning, checking, or servicing the equipment.

1. Close the agitator shut-off valve.
2. Shut off the air supply to any accessories such as feed pumps or an elevator.

## Setup

<p>To reduce the risk of serious injury from moving parts and splashing fluid, always shut off the agitator before you raise, check, or repair the agitator.</p>				

1. Before turning on supply air, make sure all valves are in the CLOSED or OFF position.
  - a. For elevator packages, make sure that the elevator control selector is in the OFF position.
  - b. Make sure that the agitator shut-off valve is CLOSED.
  - c. If using a feed pump, make sure that the pump shut-off valve is CLOSED.
2. Turn on the air supply to the system.

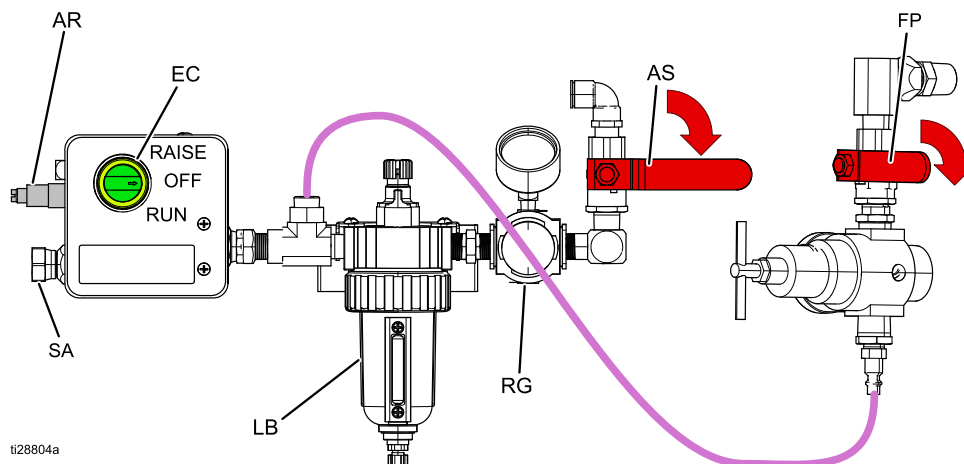

ti28804a

Ref.	Description
AR	Air Restrictor (Elevator Speed)
EC	Elevator Control Selector
AS	Agitator Shut Off Valve
FP	Feed Pump Shut Off Valve
SA	Supply Air Inlet
LB	Agitator Lubricator
RG	Agitator Regulator and Gauge

## Using the Elevator (included in some packages)

Refer to the Elevators and Pump Supports Manual 306287 for detailed information about using the elevator.

The elevator air control has three settings: RAISE, OFF, and RUN.

- RAISE allows the elevator to be raised and disables the agitator and feed pump air.
- OFF turns off all air pressure. If the elevator is raised, OFF will lower the elevator.
- RUN enables the agitator and feed pump air.

A restrictor valve on the elevator air line slows the elevator for safe operation.

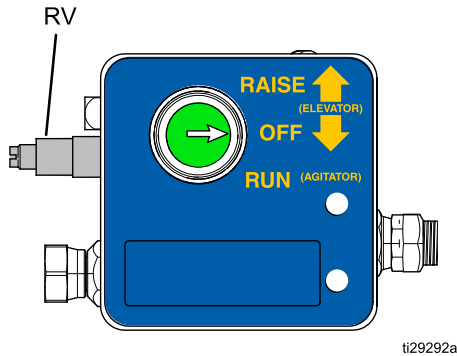

## Using the Agitator

Make sure that the agitator shut-off valve is in the CLOSED position and the regulator is turned all the way down.

If used, turn the elevator control to RUN.

Turn the agitator shut-off valve to the OPEN position.

Slowly open the regulator valve to increase agitator speed until the desired speed is reached.

**NOTE:** Always maintain moderate agitator speed. Excessive agitator speed may cause vibration, foaming of fluid, and increased wear on parts.

### NOTICE

To prevent air motor failure and possible damage to equipment, always keep the air motor properly lubricated.

The Xtreme-Duty Agitator is provided with an air line lubricator to aid in proper maintenance. Fill the lubricator with SAE #10 light oil and set the lubricator feed rate at 1 drop of oil per minute for high speed or continuous duty usage. Do not overfeed oil or exhaust air may become contaminated. To manually lubricate the air motor, see [Lubricating the Agitator Air Motor, page 15](#).

## Using the Feed Pump (included in some packages)



Fluid under high pressure can be injected through the skin and cause serious injury. To reduce the risk of an injury from injection, splashing fluid, or moving parts, follow the Pressure Relief Procedure whenever you:

- are instructed to relieve the pressure,
- stop spraying,
- check or service any of the system equipment,
- or install or clean the spray tips.



Refer to the feed pump manual and component manual for any dispense equipment used for specific operation and pressure relief instructions.

## Feed Pump Pressure Relief Procedure

For feed pump pressure relief information, refer to the appropriate feed pump manual.



[Related Manuals, page 3](#).

## Service

				
---	---	---	--	--

Hazardous fluids or toxic fumes can cause serious injury or death if splashed in the eyes or on the skin, swallowed, or inhaled. When flushing the air motor, keep your face away from the exhaust port, and wear the appropriate protective clothing, gloves, eyewear, and respirator.

### Flushing the Agitator Air Motor

				
---	---	--	--	--

Do not use kerosene or other flammable solvents to flush the air motor. Flushing with flammable solvents could cause fire or explosion and result in serious injury or property damage.

If the air motor is sluggish or inefficient, follow this procedure in a well ventilated area.

1. Disconnect the air line and muffler (08) from the motor (W).
2. Add several teaspoons of non-flammable solvent, or spray the solvent directly into the motor air tube connector (R).

**NOTE:** The recommended solvent for air motors and lubricated pumps is Gast® Flushing Solvent (Part AH255 or AH255A) or Penetone Inhibisol® Safety Solvent.

3. Reconnect the air line, and slowly increase the air pressure until there is no trace of solvent in the exhaust air.
4. Reconnect the muffler (08).
5. Re-lubricate the motor with a squirt of lightweight oil into the motor air tube connector (R).

## Lubricating the Agitator Air Motor

<b>NOTICE</b>
To prevent air motor failure and possible damage to equipment, always keep the air motor properly lubricated.

If an air line lubricator is not installed, the air motor must be manually lubricated every 8 hours. Lubricate the agitator air motor by placing 10–20 drops of SAE #10 light oil in the motor's air inlet. Run the agitator for about 30 seconds.

### Lubricating the Gear Reducer

*Gear Reducer:* After the first 100 hours or two weeks of operation, remove the oil plug (T) and the oil level plug (S), drain the oil, and thoroughly flush the housing with light flushing oil.

Refill with Graco oil (part 217374) to the proper level.

Afterward, change the oil every six months or 2500 hours of operation (whichever occurs first) under normal operating conditions. More frequent oil changes are needed under severe operating conditions or in atmospheres containing excessive moisture or abrasives. Contact your Graco distributor.

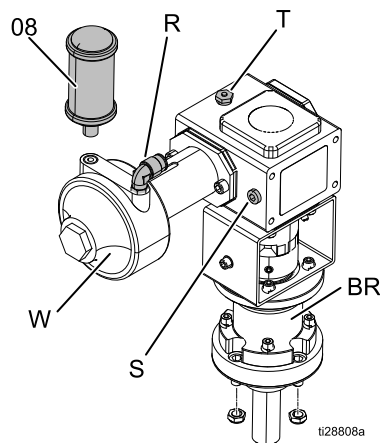

### Inspecting the Bearing Block

Every six months or 2500 hours of operation (whichever comes first), inspect the bearing block (BR). This can be performed before or after gear reducer oil changes.

With the agitator running slowly, place a hand on the side of the bearing block (BR). There should be no excessive vibration or grinding. Do not attempt to repair the bearing block or gear reducer. Contact your Graco Distributor.

*Notes*

# Notes



# Parts

## Xtreme-Duty Agitator 25A598

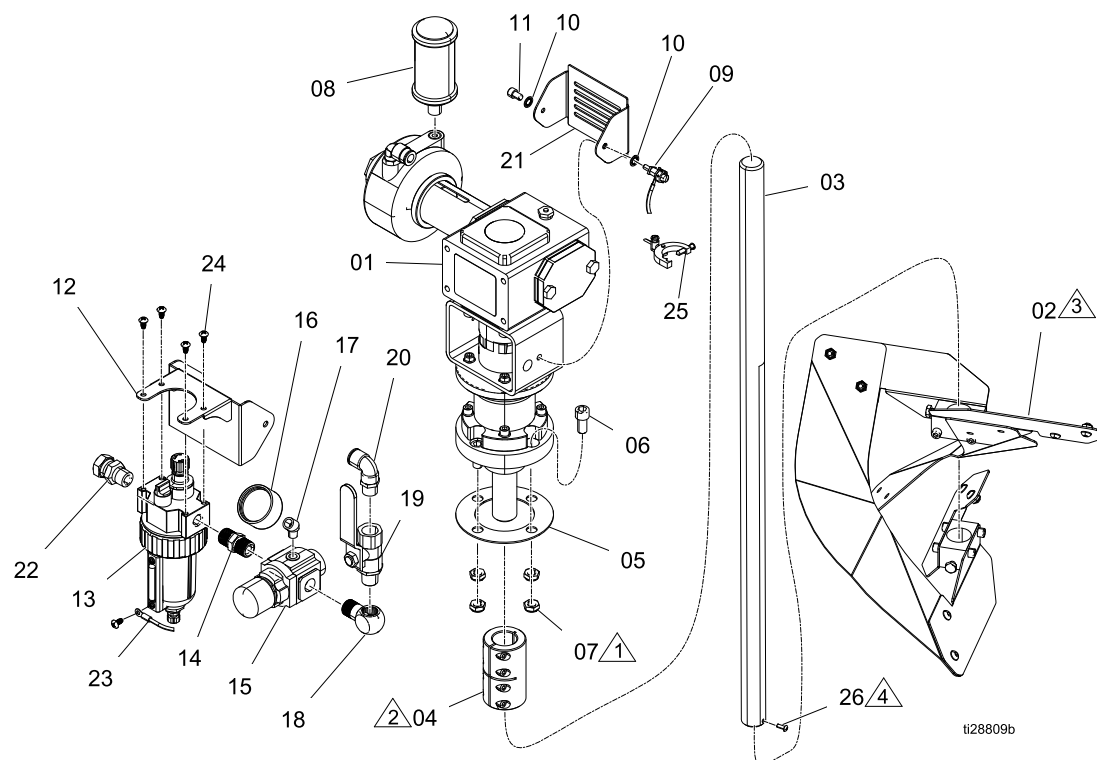

Ref.	Part	Description	Qty.	Ref.	Part	Description	Qty.
01†		AGITATOR, drive train	1	19	113333	VALVE, ball, vented	1
02	17J004	BLADE, Xtreme-Duty Agitator	1	20	16F151	FITTING, connector	1
03	16T396	SHAFT, agitator	1	21		BRACKET, guard, coupling	1
04	16T245	COUPLER, shaft	1	22	155665	FITTING, swivel, 3/8 in.	1
05	24P837	GASKET, agitator	1	23	127438	WIRE, ground	1
06	109212	SCREW, cap	4	24		SCREW, self-tapping	4
07	125204	NUT, lock, 3/8-16	4	25	237569	WIRE, grounding	1
08	129069	MUFFLER, air, exhaust	1	26		SCREW, buton, #6-32 x .38	1
09	15R343	CLAMP, grounding	1	27	113500	THREAD LOCKER (not shown)	1
10	157021	WASHER, lock, int. tooth	2				
11	C19798	SCREW, SHCS	1				
12		BRACKET, air lubricator	1	1		Tighten nuts to 30 ft-lb (40.6 N•m) when installing onto the drum cover.	
13	214847	LUBRICATOR, air	1	2		Tighten all four screws to 15 ft-lb (20.3 N•m).	
14	156849	FITTING, nipple, 3/8 in.	1	3		Apply thread locker (27) to shaft setscrews and tighten to 13 ft-lb (17.6 N•m).	
15	15T539	REGULATOR, air	1	4		Apply thread locker (27) to screws and tighten to 1-2 ft-lb (1.3-2.7 N•m).	
16	113911	GAUGE	1	†		See <a href="#">Xtreme-Duty Agitator Drive Train, page 18</a> for driver part details.	
17	113630	FITTING, 45 degree, 1/8 in.	1				
18	155699	FITTING, elbow, 3/8 in.	1				

# Xtreme-Duty Agitator Drive Train

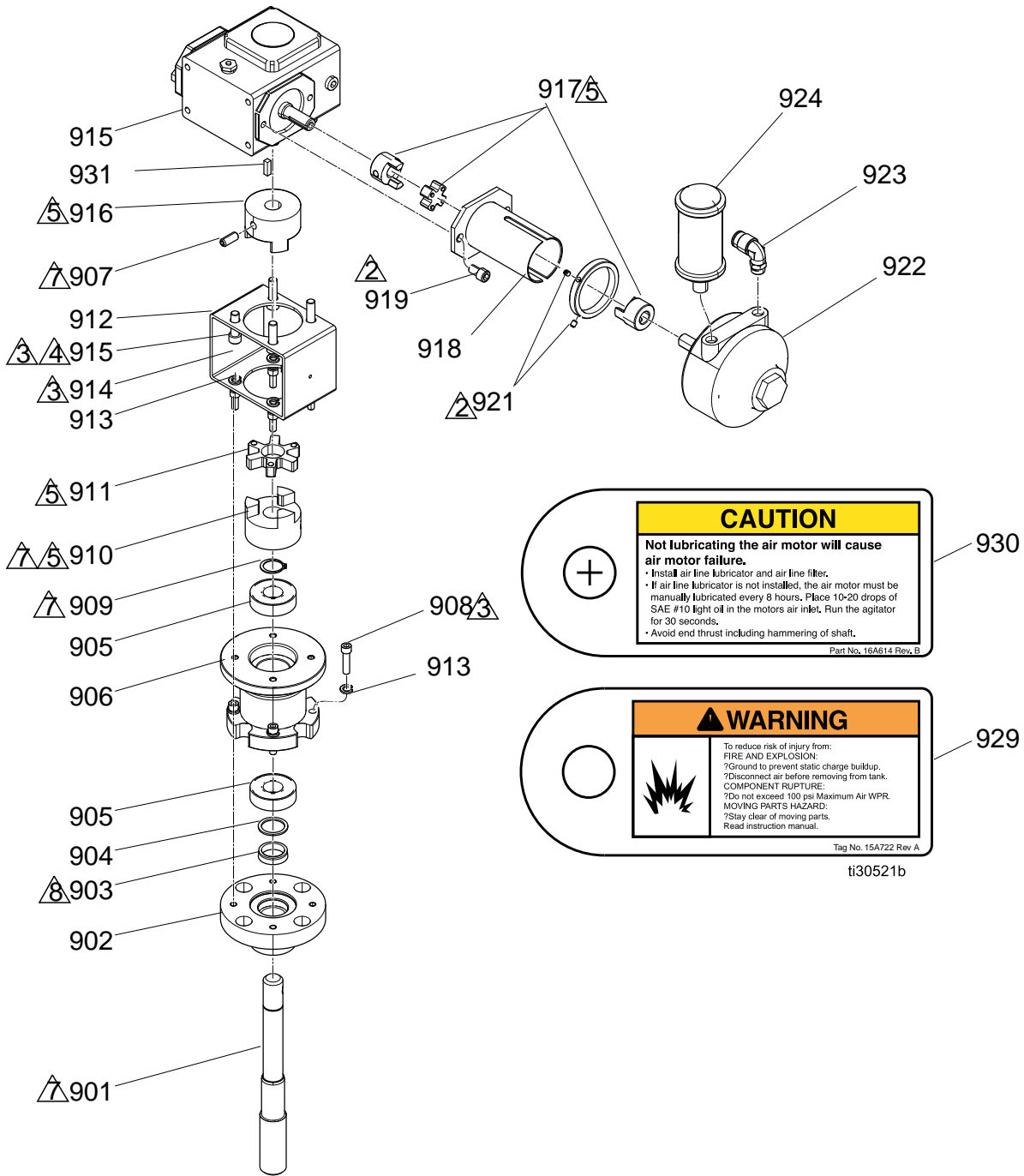

Ref.	Part	Description	Qty.	Ref.	Part	Description	Qty.
901	16P919	SHAFT, agitator, upper	1	922	111310	MOTOR, air, rotary	1
902	16U219	HOUSING, agitator	1	923	115841	FITTING, elbow	1
903		SEAL, PTFE	1	924	129069	MUFFLER, air, exhaust	1
904		SPACER, shaft, agitator	1	929▲	15A722	LABEL, warning	1
905	122774	BEARING, 3/4 ID x 1-3/4 OD	2	930▲	16A614	LABEL, caution	1
906	16P920	HOUSING, bearing, agitator	1	931	120376	KEY, square, .188 x .62	1
907		SCREW, SHCS, 5/16-18 x 0.75	2				
908	112222	SCREW, socket cap head	4	▲	Replacement Warning and Caution labels, signs, tags, and cards are available at no cost.		
909		RING, retaining, external, 0.75	1				
910	122761	HOUSING, alignment, hub	1	△ 1	Apply pipe sealant to all non-swiveling pipe threads.		
911	112760	COUPLING, alignment, disk, TPE	1	△ 2	Apply low strength threadlocker.		
912	16P922	BRACKET, adapter, agitator	1	△ 3	Apply blue thread locker.		
913	C19209	WASHER, lock	8				
914	101682	SCREW, socket cap head	4	△ 4	Remove four screws from gear reducer (915). Pass them through bracket (912) and back into gear reducer (915) then torque to 150-170 in-lb (17-19 N•m).		
915	181794	GEAR, reducer	1	△ 5	Leave a 0.015 in gap between each half of couplings (910, 911, 916, 917).		
916	16P923	COUPLER, adapter	1	△ 7	<i>When ordering a replacement coupling:</i> Remove set screw supplied with couplings (910, 916) and discard. Replace with set screw (931).		
917	100828	COUPLING, flexible	1	△ 8	Open side of u-cup seal (903) must face down inside housing (902).		
918	16T063	COLLAR, mounting	1				
919	116940	SCREW, SHCS, 5/16-18	2				
920	181849	COLLAR	1				
921	101118	SCREW	2				

### Xtreme-Duty Agitator Packages 25A599 – 25A604

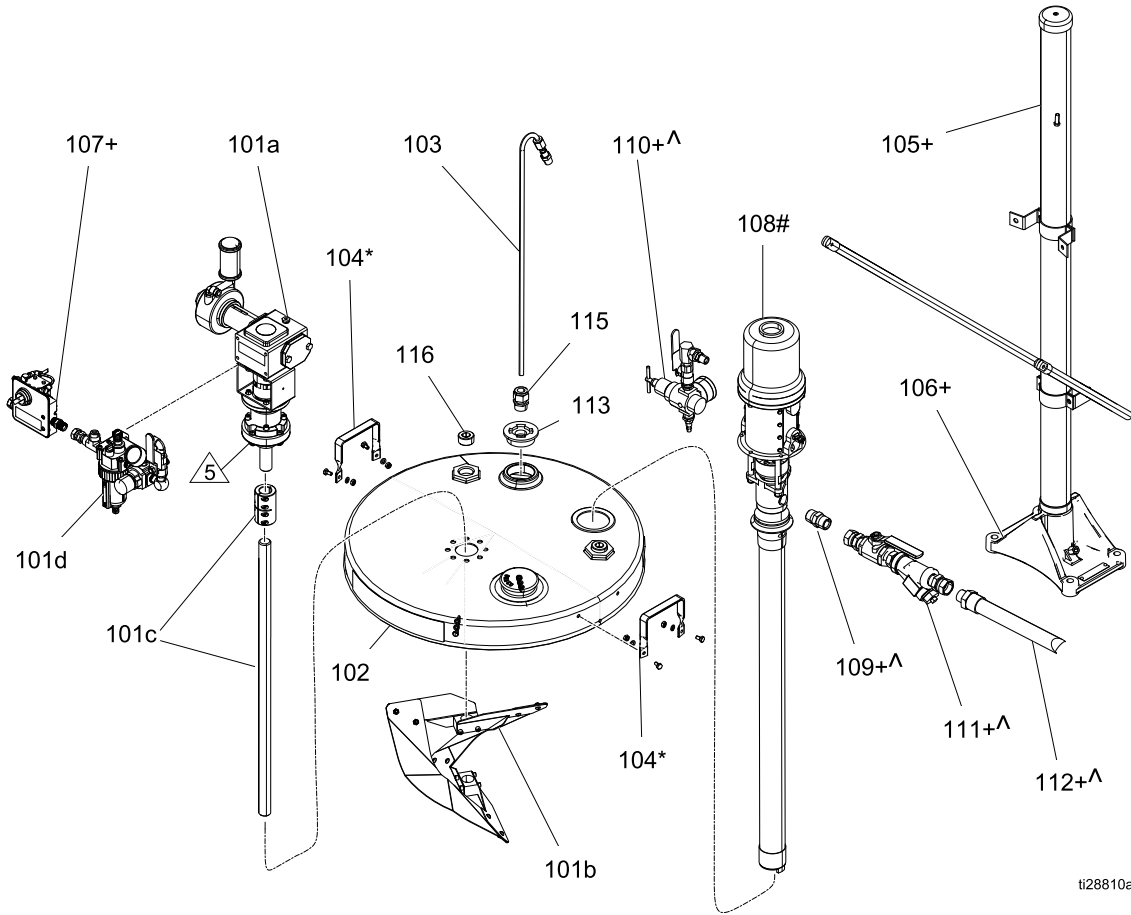

ti28810a

Ref.	Part	Description	Qty.	Ref.	Part	Description	Qty.
101	25A598	Xtreme-Duty agitator	1	112+^	217382	HOSE, 3/4 in., 10 ft	1
102	17J006	COVER, drum, agitator	1	113	128689	PLUG, 2 in. npt with 3/4 knockout	1
103	15T396	TUBE, recirculation	1	114	121378	PLUG, 2 in. npt (not shown)	1
104*	237524	KIT, handle, drum cover	1	115		BUSHING, strain relief	1
105+	204385	ELEVATOR	1	116	121497	PLUG, pipe, headless, 1 in. npt	2
106+	237578	SUPPORT, drum cover	1				
107+	25C013	AIR CONTROL, elevator	1				
108#	218956	PUMP, Monark, 5:1 cs	1				
	224350	PUMP, Monark, 5:1 sst	1				
	239326	PUMP, President, 10:1 cs	1				
	224348	PUMP, President, 10:1 sst	1				
109+^	119992	FITTING, nipple, 3/4 in.	1				
110+^	248829	KIT, regulator, feed pump	1				
111+^	256653	KIT, fluid strainer	1				

5 Tighten screws and nuts mounting to drum cover to 30 ft-lb (40.6 N•m).

\* Kit includes two handles, on package 25A599 only

+ Included with packages 25A600–25A604 only

^ Included in Feed Accessory Kit 17K401

# Varies, with packages 25A601–25A604

# Technical Data

<b>Xtreme-Duty Agitator Model 25A598</b>		
	<b>U.S.</b>	<b>Metric</b>
Maximum Air Inlet Pressure	100 psi	0.7 MPa, 7 bar
Gear Reducer Ratio	20:1 shaft speed is 1/20 air motor speed	
Maximum Recommended Shaft Speed	60 rpm	
Air Consumption at 30 rpm	7 cfm at 20 psi 20 cfm at 80 psi	3.3 L/s at 1.4 bar 9.3 L/s at 5.5 bar
Air Consumption at 60 rpm	11 cfm at 20 psi 30 cfm at 80 psi	5.2 L/s at 1.4 bar 14 L/s at 5.5 bar
Air Consumption Maximum Free Speed at 100 psi (0.7 MPa, 7 bar)	60 cfm	28 L/s
Maximum Torque at Maximum Recommended Speed	1000 in-lb (100 psi air pressure)	113 N•m (0.7 MPa, 7 bar air pressure)
Stall Torque at Maximum Air Inlet Pressure	1120 in-lb	127 N•m
Span (Diameter) of Agitator Blades	13.75 in.	349 mm
Width of Agitator Blades	3 in.	76 mm
Height of Agitator Blades	10.25 in.	260 mm
Air Inlet Size	3/8 in. nps(f)	
Ambient Temperature Range	32° F – 122° F	0° C – 50° C
Wetted Parts	303, 304, and 18–8 grades of stainless steel	
Parts which may come in contact with fluid	303 stainless steel, PTFE, carbon steel, zinc plating	
Weight	50 lb	22.6 kg
Noise Level:		
Typical operating conditions	Sound pressure* 68 dB(A)	
	Sound power** 82 dB(A)	
Maximum rpm at 100 psi (0.7 MPa, 7 bar)	Sound pressure* 74 dB(A)	
	Sound power** 86 dB(A)	
* Tested at a distance of 1 meter (3.2 feet) from equipment		
* * Tested per ISO 9614–2		

# Graco Standard Warranty

Graco warrants all equipment referenced in this document which is manufactured by Graco and bearing its name to be free from defects in material and workmanship on the date of sale to the original purchaser for use. With the exception of any special, extended, or limited warranty published by Graco, Graco will, for a period of twelve months from the date of sale, repair or replace any part of the equipment determined by Graco to be defective. This warranty applies only when the equipment is installed, operated and maintained in accordance with Graco's written recommendations.

This warranty does not cover, and Graco shall not be liable for general wear and tear, or any malfunction, damage or wear caused by faulty installation, misapplication, abrasion, corrosion, inadequate or improper maintenance, negligence, accident, tampering, or substitution of non-Graco component parts. Nor shall Graco be liable for malfunction, damage or wear caused by the incompatibility of Graco equipment with structures, accessories, equipment or materials not supplied by Graco, or the improper design, manufacture, installation, operation or maintenance of structures, accessories, equipment or materials not supplied by Graco.

This warranty is conditioned upon the prepaid return of the equipment claimed to be defective to an authorized Graco distributor for verification of the claimed defect. If the claimed defect is verified, Graco will repair or replace free of charge any defective parts. The equipment will be returned to the original purchaser transportation prepaid. If inspection of the equipment does not disclose any defect in material or workmanship, repairs will be made at a reasonable charge, which charges may include the costs of parts, labor, and transportation.

**THIS WARRANTY IS EXCLUSIVE, AND IS IN LIEU OF ANY OTHER WARRANTIES, EXPRESS OR IMPLIED, INCLUDING BUT NOT LIMITED TO WARRANTY OF MERCHANTABILITY OR WARRANTY OF FITNESS FOR A PARTICULAR PURPOSE.**

Graco's sole obligation and buyer's sole remedy for any breach of warranty shall be as set forth above. The buyer agrees that no other remedy (including, but not limited to, incidental or consequential damages for lost profits, lost sales, injury to person or property, or any other incidental or consequential loss) shall be available. Any action for breach of warranty must be brought within two (2) years of the date of sale.

**GRACO MAKES NO WARRANTY, AND DISCLAIMS ALL IMPLIED WARRANTIES OF MERCHANTABILITY AND FITNESS FOR A PARTICULAR PURPOSE, IN CONNECTION WITH ACCESSORIES, EQUIPMENT, MATERIALS OR COMPONENTS SOLD BUT NOT MANUFACTURED BY GRACO.** These items sold, but not manufactured by Graco (such as electric motors, switches, hose, etc.), are subject to the warranty, if any, of their manufacturer. Graco will provide purchaser with reasonable assistance in making any claim for breach of these warranties.

In no event will Graco be liable for indirect, incidental, special or consequential damages resulting from Graco supplying equipment hereunder, or the furnishing, performance, or use of any products or other goods sold hereto, whether due to a breach of contract, breach of warranty, the negligence of Graco, or otherwise.

## FOR GRACO CANADA CUSTOMERS

The Parties acknowledge that they have required that the present document, as well as all documents, notices and legal proceedings entered into, given or instituted pursuant hereto or relating directly or indirectly hereto, be drawn up in English. Les parties reconnaissent avoir convenu que la rédaction du présente document sera en Anglais, ainsi que tous documents, avis et procédures judiciaires exécutés, donnés ou intentés, à la suite de ou en rapport, directement ou indirectement, avec les procédures concernées.

## Graco Information

For the latest information about Graco products, visit [www.graco.com](http://www.graco.com). For patent information, see [www.graco.com/patents](http://www.graco.com/patents).

**To place an order**, contact your Graco Distributor or call to identify the nearest distributor. **Phone:** 612-623-6921 **or Toll Free:** 1-800-328-0211 **Fax:** 612-378-3505

All written and visual data contained in this document reflects the latest product information available at the time of publication.

Graco reserves the right to make changes at any time without notice.  
Original Instructions. This manual contains English. MM **3A4032**

**Graco Headquarters:** Minneapolis **International Offices:** Belgium, China, Japan, Korea

**GRACO INC. AND SUBSIDIARIES • P.O. BOX 1441 • MINNEAPOLIS MN 55440-1441 • USA**

**Copyright 2016, Graco Inc. All Graco manufacturing locations are registered to ISO 9001.**

[www.graco.com](http://www.graco.com)  
Revision B — June 2017